

VHS WLED Pixel Workshop

Guide Jan 2023

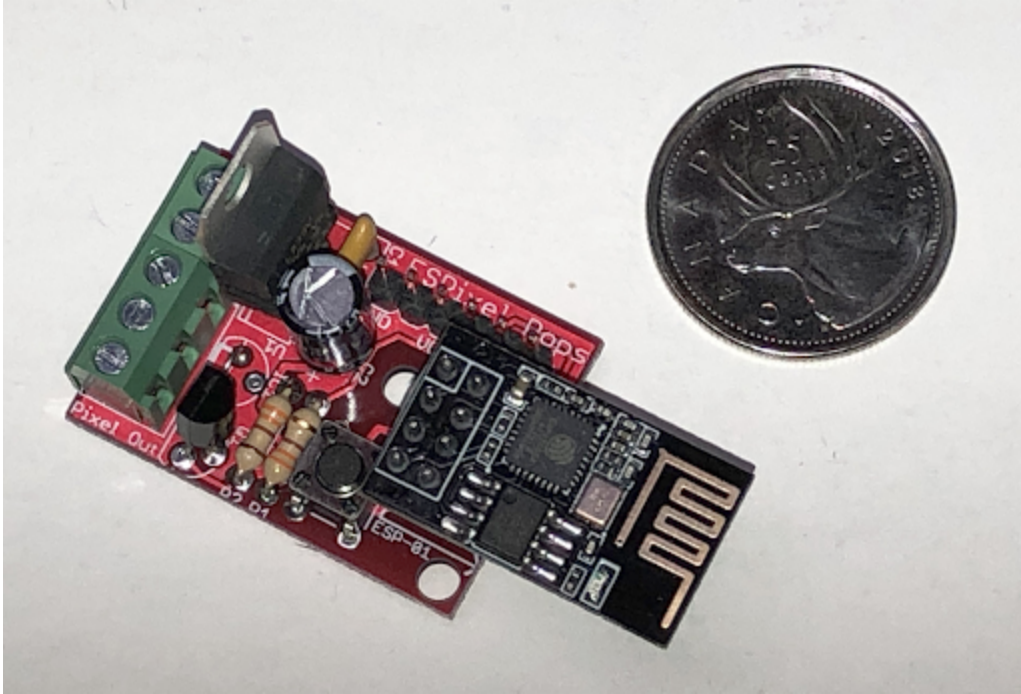

Thanks for joining the [VHS](#) WLED pixel controller workshop. This guide will show you how to assemble the pixel controller and how to set up the [WLED](#) firmware on it. WLED is an incredible pixel controller application that supports all sorts of addressable LED effects and animations. Configuration and control is done via a web page (also supports an IOS and Android control application) but once configured, can be used in a stand alone mode (ideal for any project that needs LED effects). WLED supports a wide range of addressable RGB LED pixels which are available in a [wide range of styles](#).

Some WLED features include:

- WS2812FX library integrated for over 100 special effects
- Has a capacity of over 500 pixels per controller
- Segments to set different effects and colors to parts of the LEDs
- Access Point and station mode - automatic failsafe AP
- Support for RGBW strips
- Allow presets to save and load colors/effects easily, supports cycling through them.
- Configurable Auto Brightness limit for safer operation

Some WLED control options include:

- WLED app for Android and iOS
- JSON and HTTP request APIs
- MQTT
- E1.31, Art-Net, DDP and TPM2.net
- diyHue
- Hyperion
- UDP realtime
- Alexa voice control (including dimming and color)
- Sync to Philips hue lights
- Sync color of multiple WLED devices (UDP notifier)

The ESPixelPOP uses the [ESP-01 ESP8266](#) module and this allows for a very compact form factor. The only limitation of using the ESP-01 is the small size of its FLASH (1 Meg) which limits you to using a version of WLED that doesn't support OTA (Over The Air) firmware updating.

I have just touched on the basics of getting WLED running on your ESPixelPOPs. For more information of the features you can also check out:

WLED Wiki - <https://github.com/Aircoookie/WLED/wiki>

WLED Discourse Site - <https://wled.discourse.group/>

WLED Info site - <https://kno.wled.ge/>

The ESPixelPOPs PCB has only a few components (all through hole, no SMD parts) and is fairly easy to build. Since it is a small PCB you may find a bright light and perhaps magnifying reading glasses helpful. You will need the following tools and equipment to assemble your ESPixelPOP based WLED pixel controller:

- Soldering Iron & Solder
- Diagonal Cutters
- Small bladed screwdriver
- Wire Strippers

Build Guide:

Step #1 - Referring to the picture below, make sure you have all the parts required:

- 1x ESPixelPOPs PCB
- 1x 1N4148 Diode (D1)
- 2x 330 1/4W Ohm Resistor (R1 & R2)
- 1x 0.1 uF Ceramic Capacitor (C1)
- 1x 6mm PCB Push Button
- 1x 2N7000 MOSFET (Q1)
- 1x 6 Pin 2.54mm Male Header Strip
- 1x 8 Pin (2x4) 2.54mm Socket
- 1x 5 Position 3.81mm Screw Terminal Strip
- 1x 220 uF 16V Electrolytic Capacitor (C2)
- 1x LD1117V33 Voltage Regulator (U1)
- 1x ESP-01 ESP8266 Module (ESP-01)

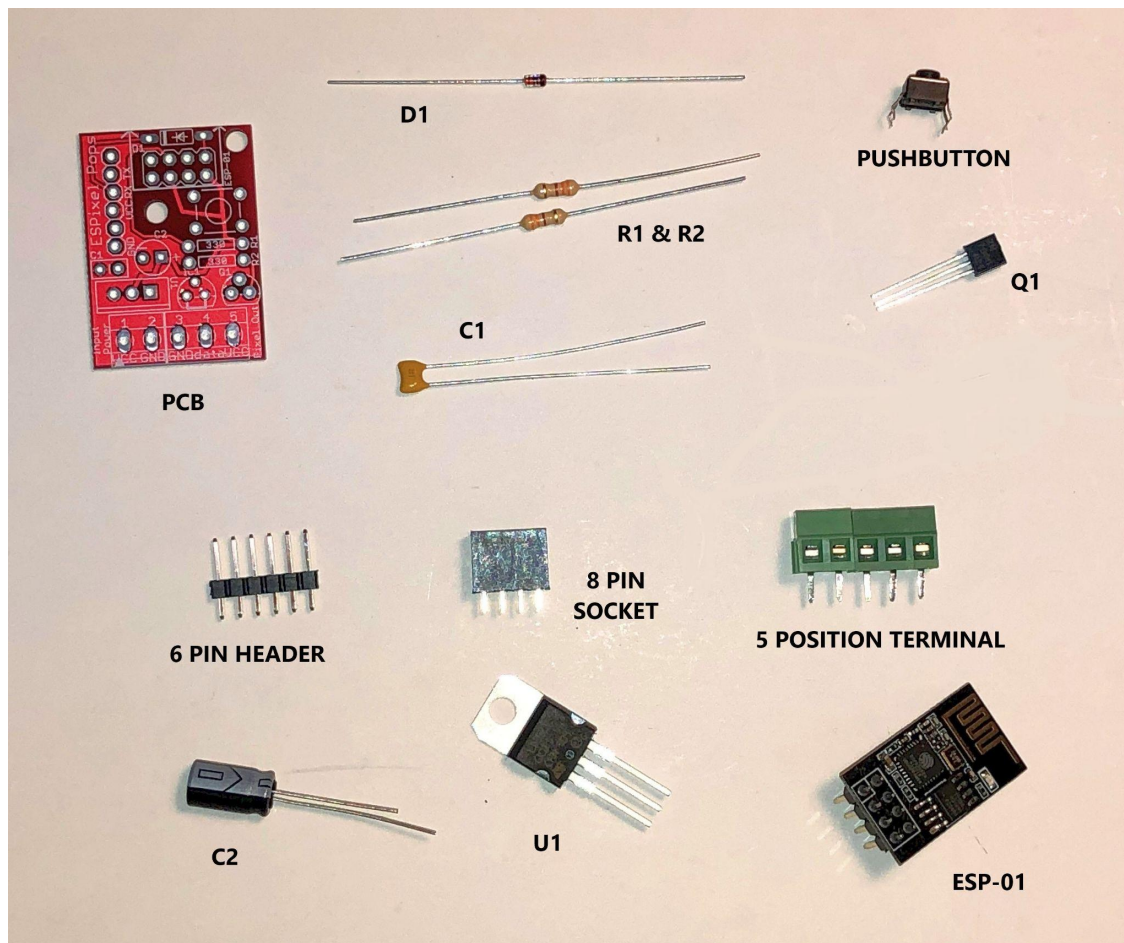

Your kit will also include:

- 1x 5V Power Supply
- 1x Power Supply Connector
- 1x 1 Meter length of WS2812 Pixel LEDs (30 pixels/ meter)
- 1x Pixel Strip Connector

Step #2 - Following the steps below, insert each part, solder it in place and snip off the extra leads. Below each set of steps is a picture showing the parts location:

- Install D1 (ensure orientation matches symbol on PCB)
- Install R1 & R2 (orientation doesn't matter)

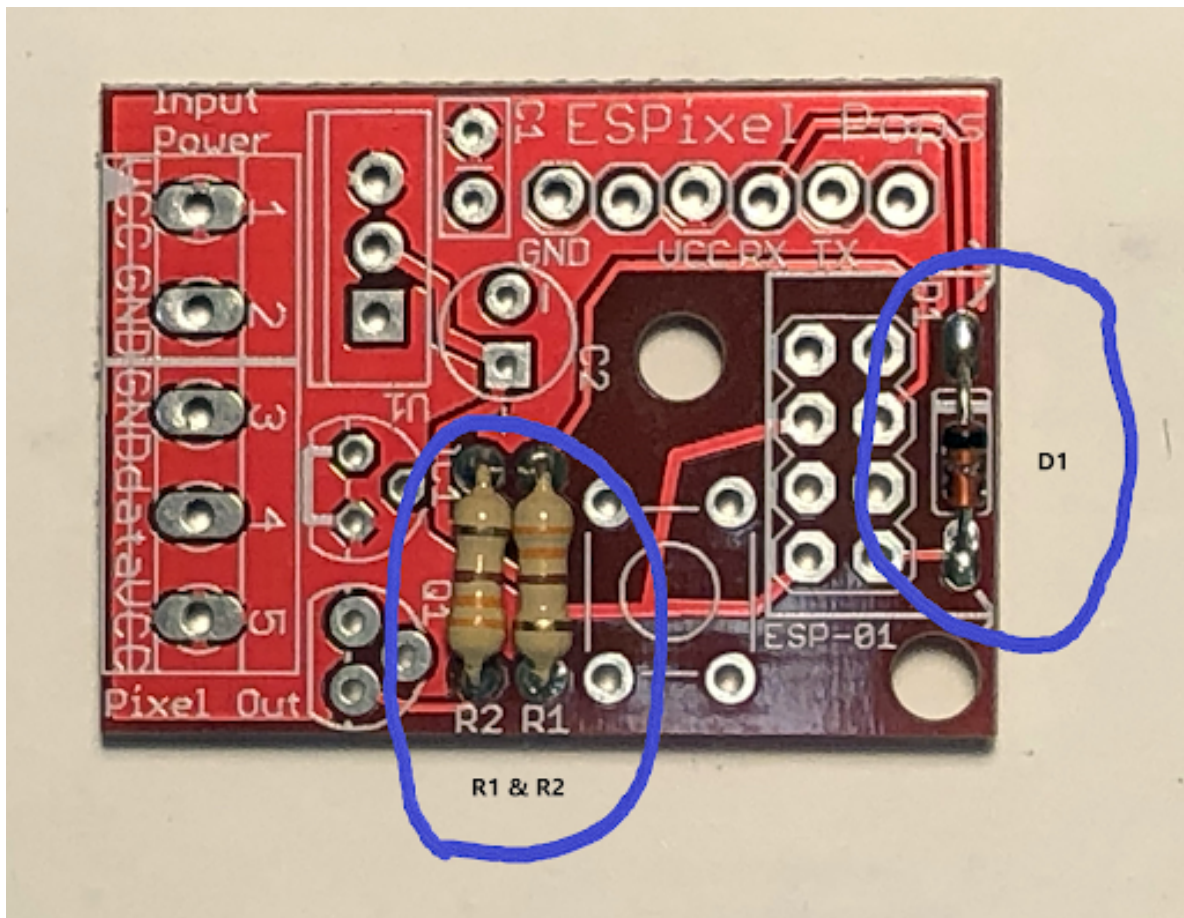

Step #3 - Following the steps below, install a wire jumper (use a lead cut off from one of the parts you have already installed), solder it in place and snip off the extra leads.

- Install Jumper in IC1 location (jumper the holes as indicated on the PCB).

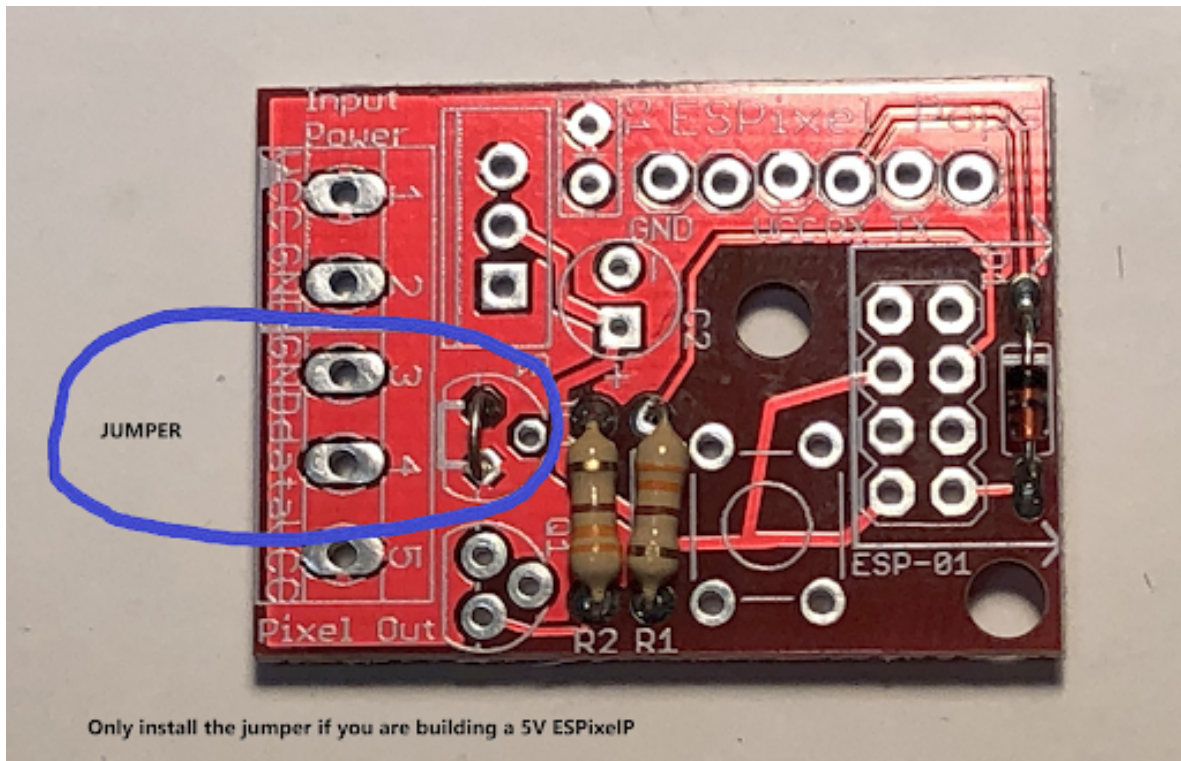

Step #4 - Following the steps below, insert each part, solder it in place and snip off the extra leads. Below each set of steps is a picture showing the parts location:

- Install C1 (orientation doesn't matter)
- Install push button (will only fit in one direction)
- Install Q1 (ensure orientation matches symbol on PCB)

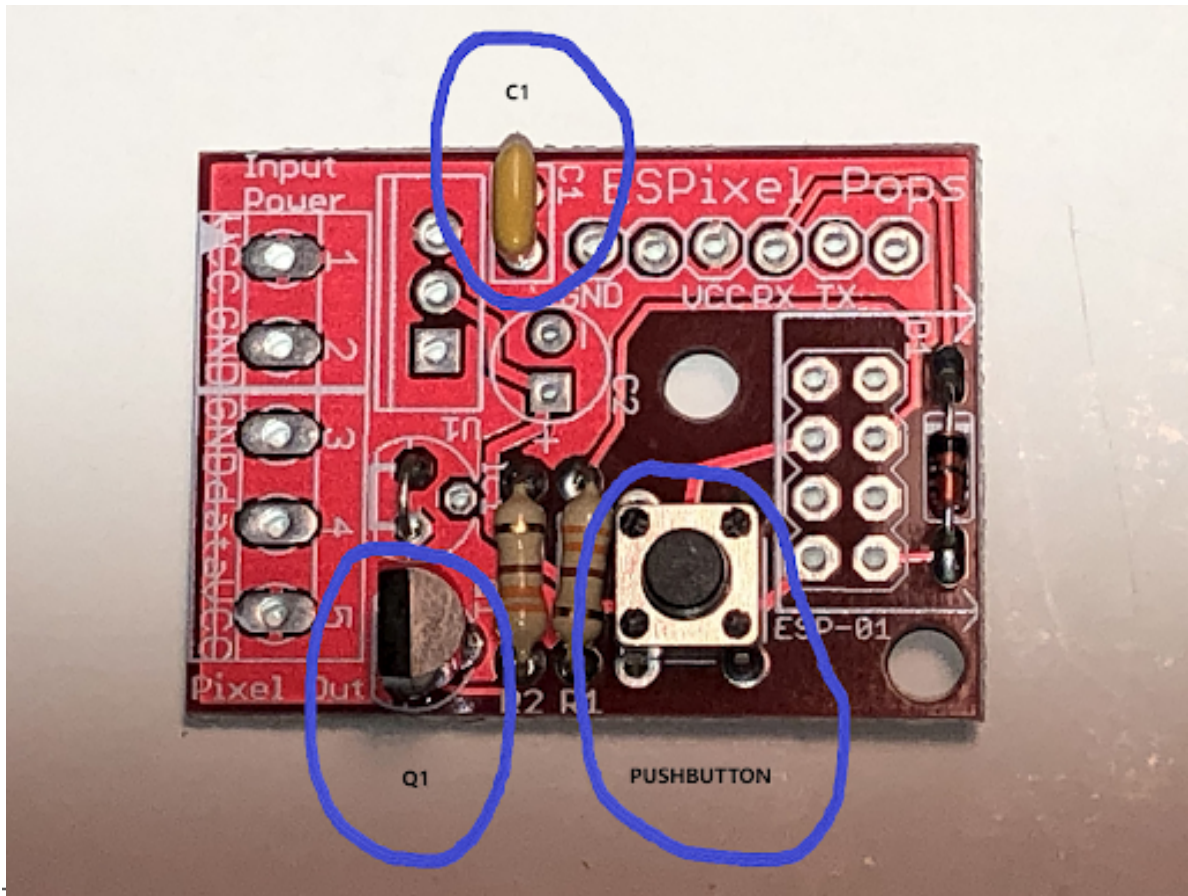

Step #5 - Following the steps below, insert each part, solder it in place (you don't have to snip the leads on these parts). Below each set of steps is a picture showing the parts location:

- Install 8 Pin Socket
- Install 6 Pin Male Header
- Install 5 Position Terminal (Ensure holes for wires face away from PCB)

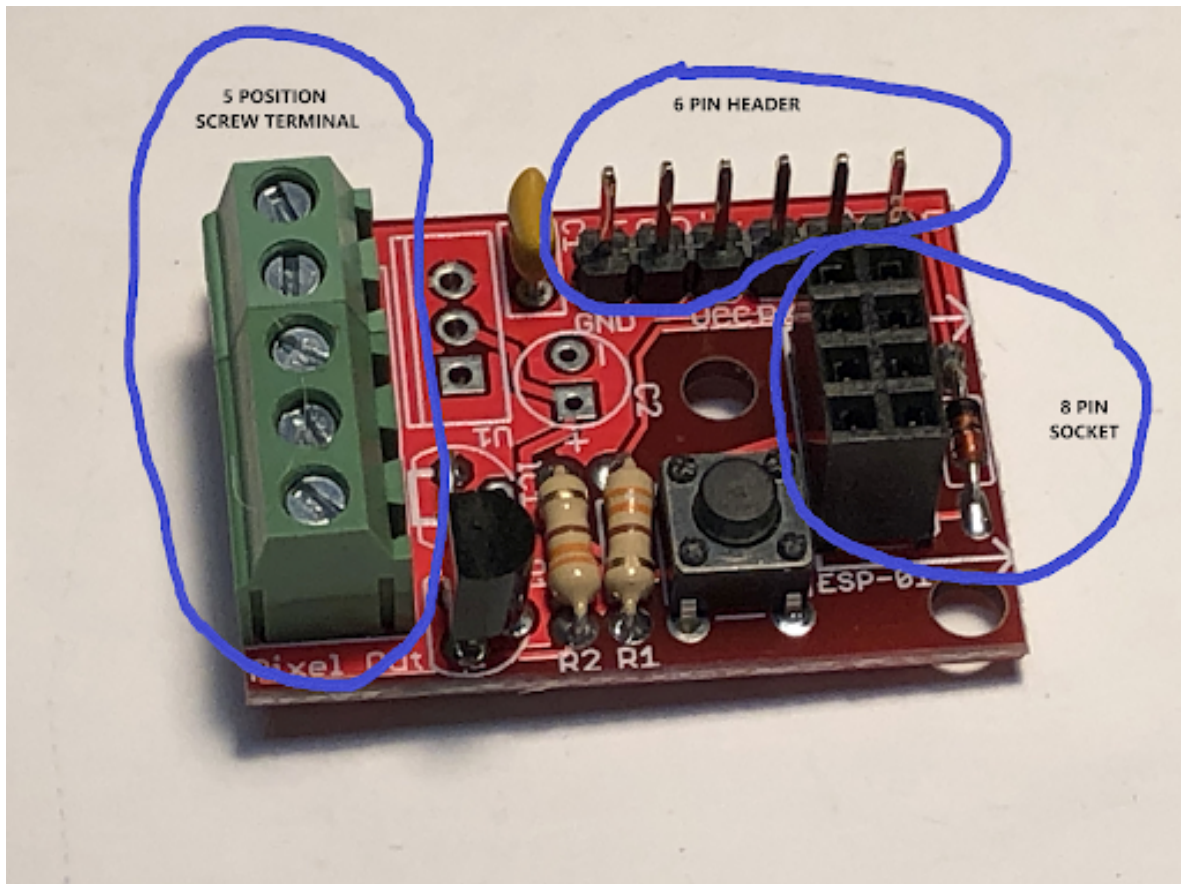

Step #6 - Following the steps below, insert each part, solder it in place and snip off the extra leads. Below each set of steps is a picture showing the parts location:

- Install C2 (Ensure long lead goes in square + hole)
- Install U1 (Ensure metal heatsink faces terminal strip)

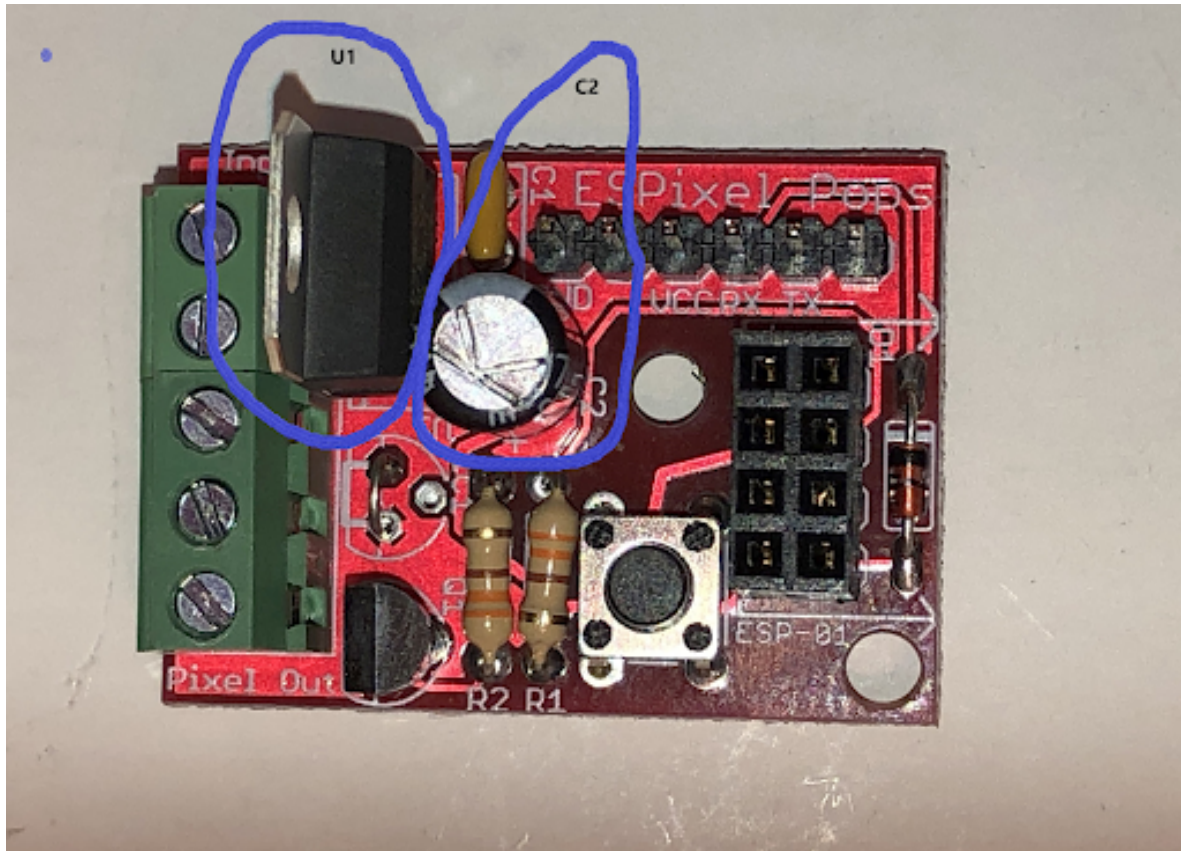

Step #7 - Install ESP-01 module

- Install ESP-01 module in 8 pin socket as shown

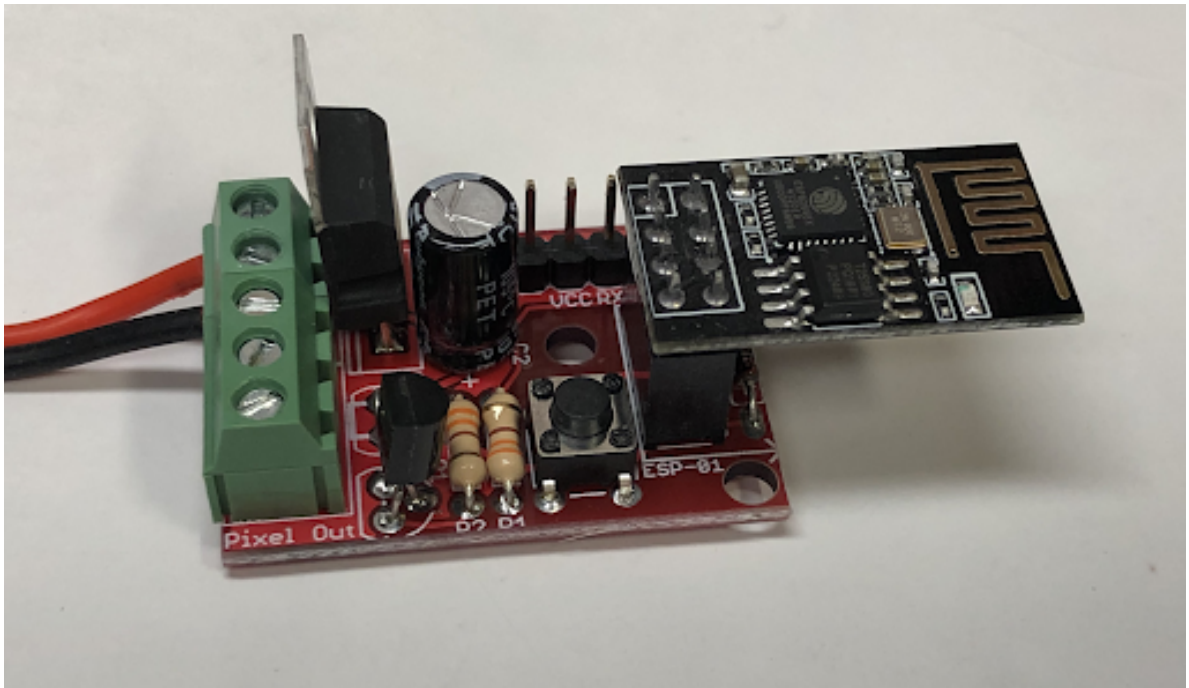

Step #8 - Connect power and pixel connectors

- Strip about 3/16" off the 2 wires that go to the power connector
- Connect Pixel Strip Connector wires to terminals 1 & 2 as follows. Twist the stranded end of each wire together to make it easier to insert into the PCB terminal connector.
(You will need to open the connector using your screwdriver before you can insert the wire and then tighten again).
 - Black Wire to GND (terminal 1)
 - Red Wire to VCC (terminal 1)

- Strip about 3/16" off the 3 wires that go to the Pixel Strip Connector.
- Connect Pixel Strip Connector wires to terminals 3, 4 & 5 as follows. Twist the stranded end of each wire together to make it easier to insert into the PCB terminal connector.
(You will need to open the connector using your screwdriver before you can insert the wire and then tighten again).
 - White Wire to GND (terminal 3)
 - Green Wire to Data (terminal 4)
 - Red Wire to VCC (terminal 5)

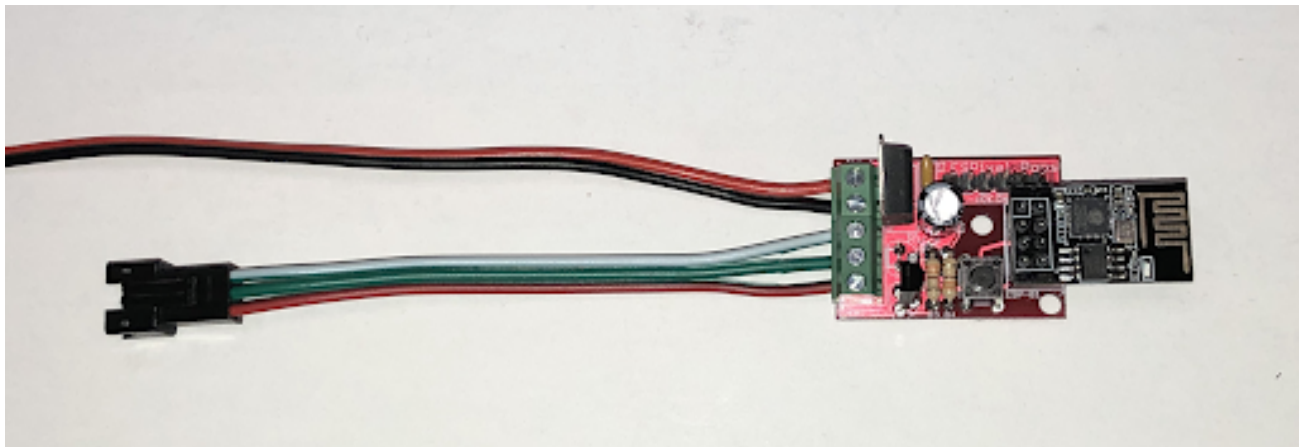

Step #9 - Insulate the extra power wires on the Pixel strip.

- On each end of the Pixel Strip you will see a connector and two extra wires (one white and one red). These wires are for power injection and are not required for our project. Cover the end of each with some electrical tape to prevent any short circuits.

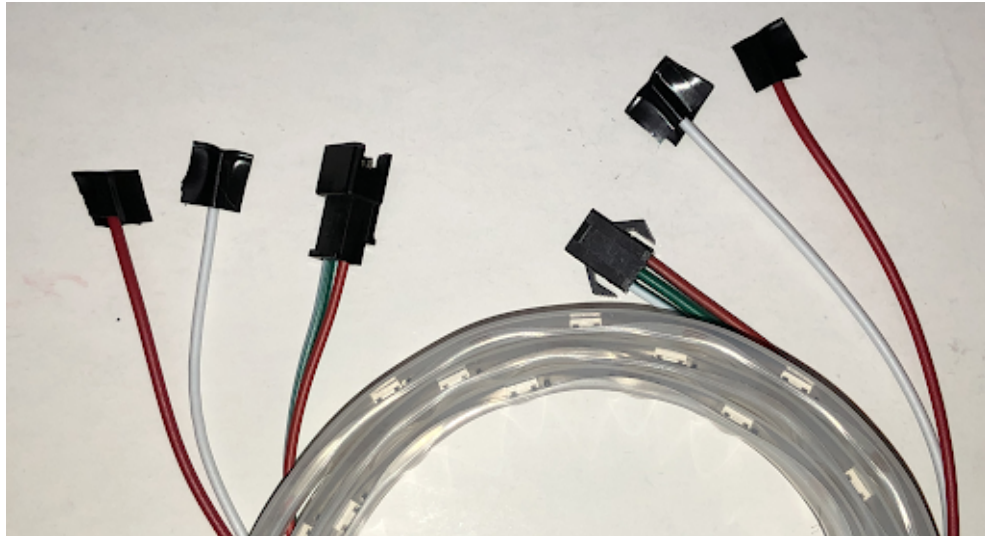

Step #10 - Connect the Pixel strip

- Connect the input connector on the Pixel Strip (it will be on the end with the arrow facing into the strip) to the matching connector on the Pixel Strip Connector. It will only connect one way

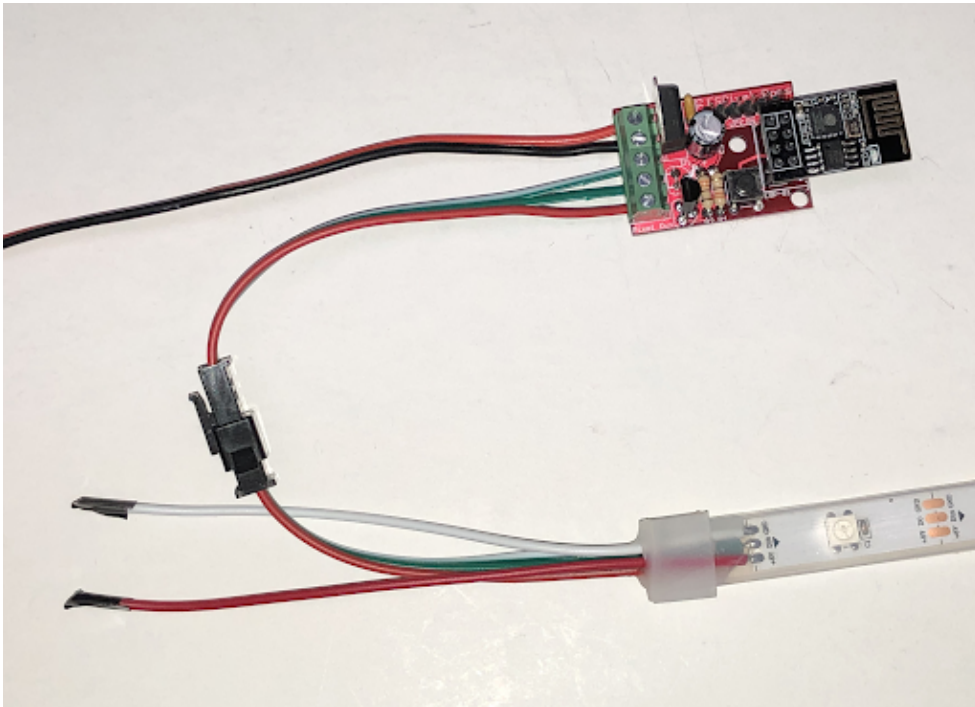

Step #11 - Confirm your connections and soldering (**have me do this**)

- Double check components are installed correctly
- Double check all solder joints to make sure they look OK
- Double check that connectors wired correctly

Step #12 - Power up WLED and start configuring!!

- Connect the 5V power supply to the power connector
- The Pixel strip should glow Orange. If it does this means all is good.
- If the LEDs don't glow Orange, disconnect the power and repeat Step#11
- Using your laptop, check for a new Wi-Fi Access Point SSID called '**WLED-AP-xx**' (the xx is the number noted on your kit bag). If you don't see it, try refreshing your AP list (on Windows 10 I turn off the Wi-Fi , then turn it back on again).
- Connect your laptop to the WLED-AP SSID using the SSID name as your password (**WLED-AP-xx**)
- Fire up a browser on your laptop and it should get automatically redirected to the WLED web page
- If not then point your browser to <http://4.3.2.1> and you should see this page:

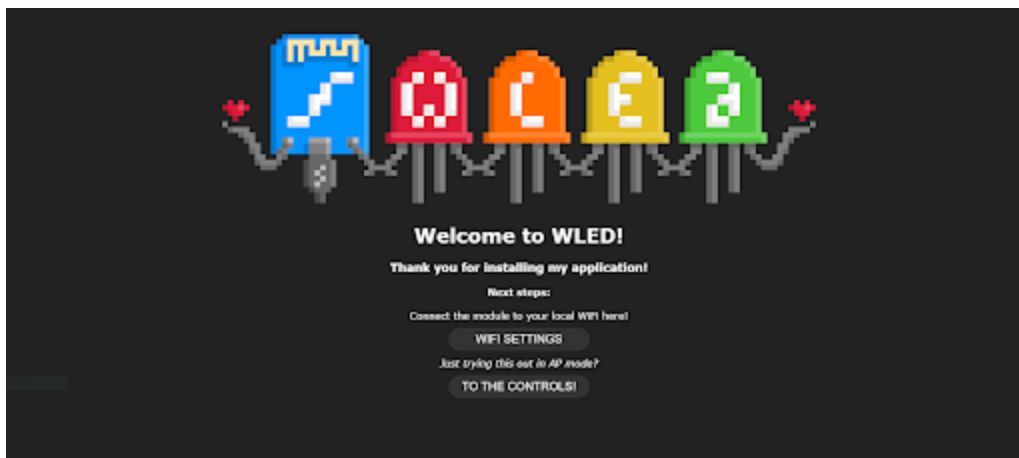

Note that in a default WLED build the SSID will be "**WLED-AP**" and the password will be "**wled-1234**". For the VHS workshops I have configured each kit with a different AP name to avoid confusion with multiple WLED controllers running.

- Click on the **WiFi SETTINGS** button
- Enter the following information as required by your Wi-Fi network
 - Network Name: (Your home Wi-Fi SSID)
 - Network Password: (Your home Wi-Fi password)
 - Static IP : (Desired IP for your home network)
 - Static Gateway: (Home network gateway IP)
 - Static subnet mask: (Home network subnet mask, typically 255.255.255.0)
- When done hit the **Save & Connect** button at the bottom of the page

Back Save & Connect

WiFi setup

Connect to existing network

Network name (SSID, empty to not connect):

Your_Network

Network password:

Static IP (leave at 0.0.0.0 for DHCP):

0 . 0 . 0 . 0

Static gateway:

0 [v] . 0 . 0 . 0

Static subnet mask:

255 . 255 . 255 . 0

Step #13 - Setup WLED

- Reconnect your laptop to your home Wi-Fi network
- Allow time for WLED to reboot
- Point your browser to the IP you configured WLED for previously
- You will get the main WLED page and now be able to control your pixels!!
- If desired there is also an [Android](#) and [iOS](#) that you can use instead of a browser to control WLED

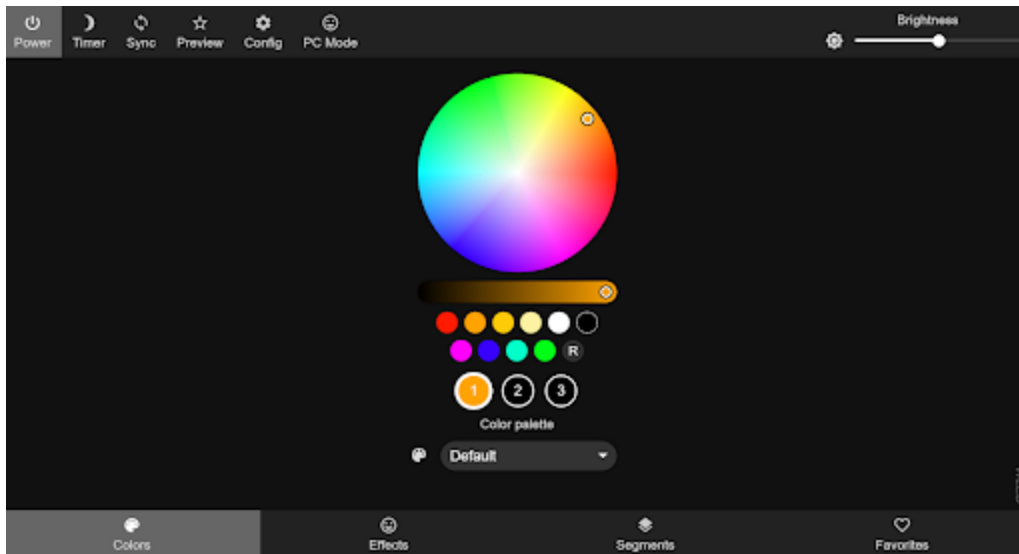

Basic Functionality:

If you have the optional Pixel strip connected to your controller it should be glowing Orange and will work with the default WLED configuration. You should be able to use the color picker wheel or the color buttons to make the strip glow any color you choose.

Select the **PC Mode** tab as this will show you the color picker, color palettes and LED effect menus on a single page.

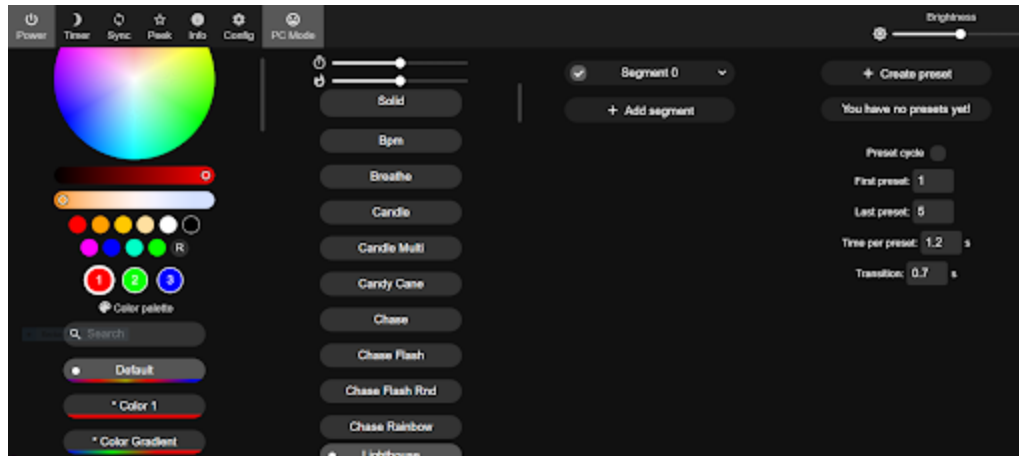

Now you can try the various effects. For each effect there is an **Effect Speed** setting and an **Effect Intensity** setting. For many effects the Intensity setting may also control some options with the effect. You can find more information here:

<https://github.com/Aircoookie/WLED/wiki/List-of-effects-and-palettes>

Total brightness of the LEDs is controlled by the Brightness slider at the top right of the window

You also have access to various palettes for the effects to use. This gives you a huge option of colors with the effects that use the palettes (not all options use palettes). Just below the color picker and above the Color Palette settings are 3 circles (Labelled 1, 2 & 3). These are the settings for your primary, secondary and tertiary colors. I find setting them for 1 = Red, 2 = Green and 3 = Blue helps with some of the effects (just click on the circle, then click on a color to set it).

The various controls give you a huge amount of options and you really have to experiment with the various choices to see the results. Different physical layouts of your LEDs will affect what patterns work best.

Setting up Presets:

Another feature of WLED is the ability to set a preset effect (or number of presets to cycle through). These preset effects can be set to start when WLED starts up, perfect for effects and props and other such projects. You can have up to 250 separate presets that WLED will cycle through. To set up presets do the following:

- Select the effect you want using the various speed, palette and intensity options
- Hit the **+ Create Preset** button
- Enter a name for you preset (I name this after the effect selected)
- Select **Save Preset**

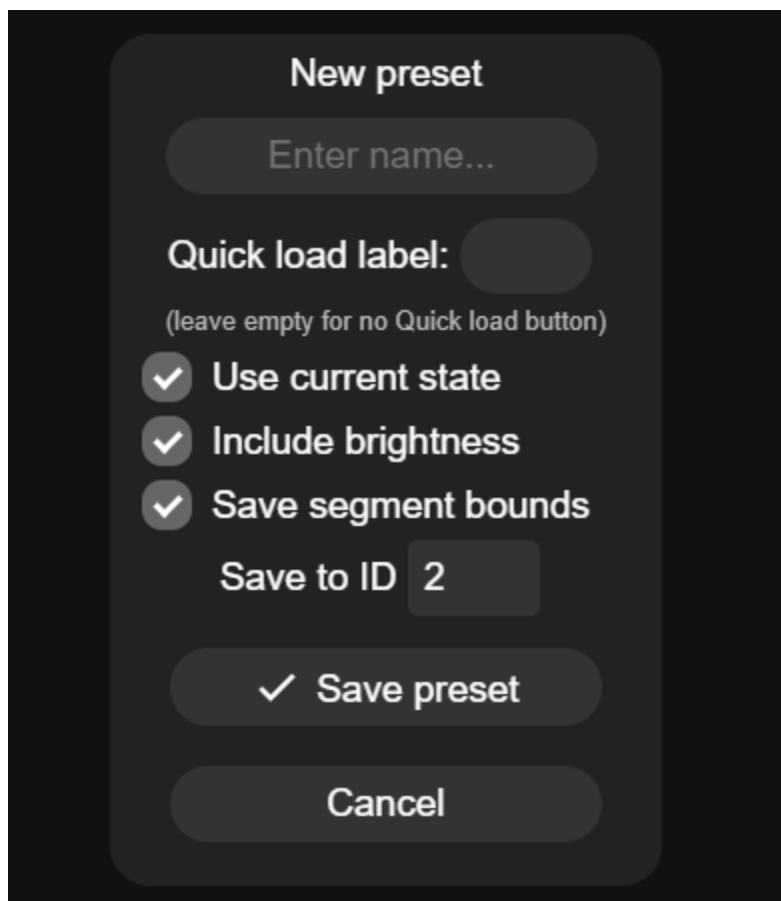

You will see the preset name in the list (with an ID number) You can add as many (up to 250) presets and they will be listed on the page. You can simply select any of them to have the effect run.

If you want to cycle through your presets do the following:

- Create and save each of your desired presets
- Configure the **First Preset ID #** you want to use
- Configure the **Last Preset ID#** you want to use
- Configure the **Time Per Preset** (in seconds) you want each preset to run for
- Configure the **Transition Time** (in seconds) you want to fade between each preset effect
- Select **Preset Cycle** and WLED will start cycling through your choices

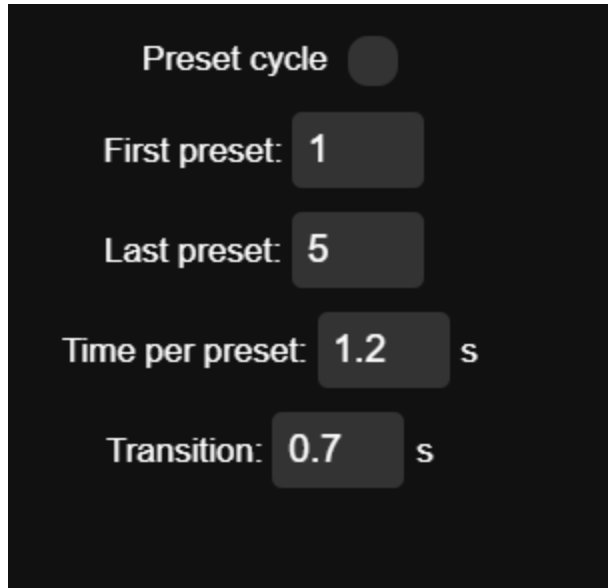

You can have either a single preset or your list of present run at bootup by doing the following:

- Create and save each of your desired presets
- Configure the preset list (if you want to use a list)
- Goto the **Config** tab
- Goto the **LED Preferences** section
- Scroll down to the **Defaults** section
- If you want a single preset to run at bootup config the preset ID # for **Apply Preset At Boot**
- If you want your preset list to run the select preset ID #1 for **Apply Preset At Boot** and select **Set Current Preset Cycle as Boot Default**

Once you have this selected the appropriate preset(s) will run as soon as the pixel controller is powered up.

Apply preset at boot (0 uses defaults)

- or -

Set current preset cycle setting as boot default:

Configuration Options:

WLED does have a multitude of options and you are best to refer to the Wiki, Discord or FAQ sites for more information (Links at the top of this guide)' However here are some typical things you may need to configure

Led Count - (Main/Config/LED Preferences/**Total LED Count**)

Set this for the number of pixels you have connected (Default = 30)

Led Type - (Main/Config/LED Preferences/**LED Output**)

Set this for the LED type (Default = WS281x)

Color Order - (Main/Config/LED Preferences/**Color Order**)

Set this for the pixel color order (Default = GRB) - Change this if you don't get the correct colors on your LEDs

Effect Direction - (Main/Config/LED Preferences/**Reverse**)

Check this to reverse the direction of the LED affects

Firmware Programming Information:

The VHS kits already have the ESP-01 programmed with the latest version of the WLED ESP-01 firmware (v0.12.0) but if you need to program your own then pay attention to these notes and procedures:

- You will need a USB to Serial TTL Adapter (3.3V or 5V Version)
- Do not use your USB-TTL adapter to power the ESPiPixelPOP during programming as it cannot supply enough current to reliably power the ESP-01 module. Make sure you power the ESPiPixelPOP board from a separate source that can supply at least 300 mA.
- Only connect the USB -TTL adapter using the GND, RX & TX connections with jumper wires. If your USB-TTL adapter has sockets do not connect it directly to the pins on the ESPiPixelPOPs board. Do not connect any of the other pins from the USB-TTL adapter.
- You can use either a 3.3V or a 5V version of a USB-TTL adapter. The diode in the ESPiPixelPOPs circuit acts as a level translator so the ESP-01 only sees the correct voltage either way.
- I have found some cheap USB-TTL adapters that just do not seem to work as well as others for programming the ESP-01 module on the ESPiPixelPOP board. If you are having issues I recommend you try a different adapter. If you still have issues you may want to make or purchase a dedicated ESP-01 programmer.

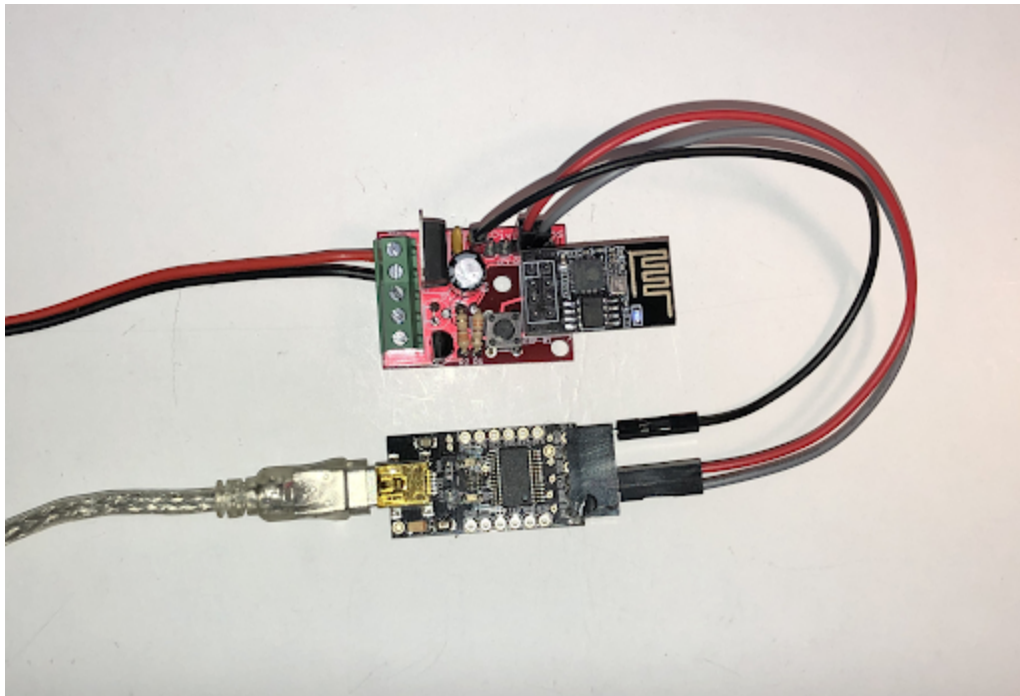

Installing WLED firmware on the ESPixelPOPs:

Step A - Get your ESPixelPOP ready

- Install ESP-01 module in 8 pin socket (ensure antenna side of module is away from the PCB)
- Connect your USB-TTL adapter to your PC and ensure it is recognized by your PC.
- Connect your USB-TTL adapter pins to the header pins on the ESPixelPOP as noted:
 - USB Adapter GND to PixelPOP GND
 - USB Adapter TXD to PixelPOP RX
 - USB Adapter RXD to PixelPOP TX

Then use one of the methods below to load the firmware. Using the precompiled firmware is by far the easiest route to follow. I would avoid using the IDE and compiling the code unless you know what you are doing.

Step B - Download the most recent WLED firmware (currently v0.12)

- Create a folder on your PC.
- Go to this page (<https://github.com/Aircoookie/WLED/releases/tag/v0.12.0>) and download **WLED_0.12.0_ESP8266_1M.bin** to the folder you previously created.

Step C - Download the ESP programming utility.

As we are using the precompiled binary (.bin file) we need a way to load it into the ESP-01 module. We will use a flash loader application called [ESPHome-Flasher](#) that has a Windows, Mac & Linux version. Note that you don't need to install this application but can just double click it in the folder you have downloaded it to.

- Go to this page (<https://github.com/esphome/esphome-flasher/releases>) and download the required flash loader. Store it in the same folder where you saved the firmware.

Step D - Upload the WLED firmware to your ESPixelPOP

- Launch the ESPHome-Flasher application
- Ensure the Serial Port dropdown box has the correct port selected for your USB-TTL adapter (You can refresh the list of available serial port devices using the button to the right of the drop down).
- Select the desired firmware file using the Browse button.
- Power cycle the ESPixelPOP but this time hold down the push button on the ESPixelPOP PCB and release after a few seconds to put it into the programming mode.
- Press the “Flash ESP” button on the ESPHome-Flasher application
- You should see the file transfer and programming progressing in the “Console” window.
- You will see a “Done! Flashing is complete!” message when done

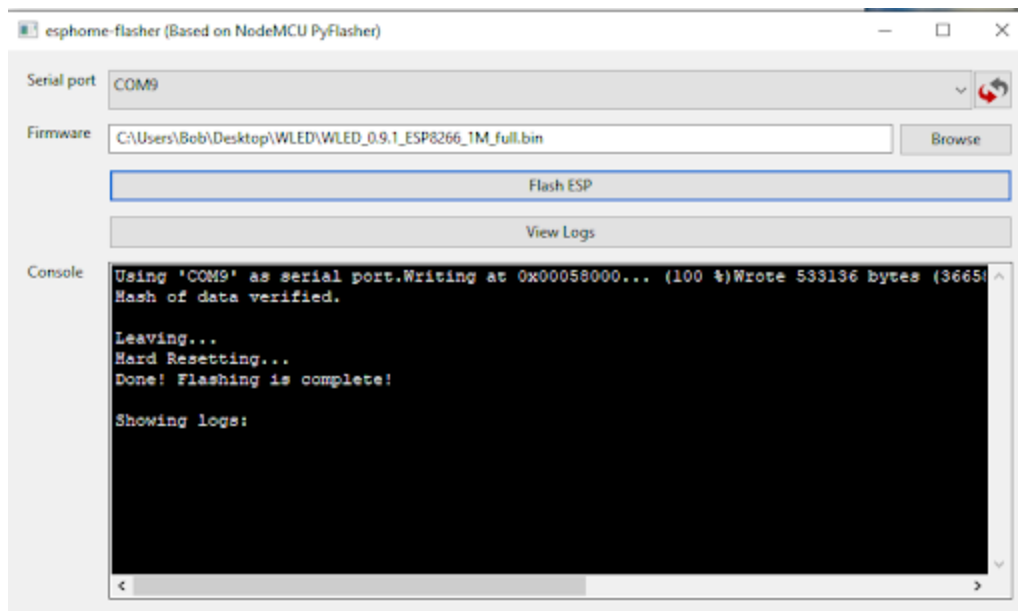

- Power cycle your ESPixelPOPs and it will boot up in AP mode allowing you to connect as described in Step #12 of the above instructions

If you have any questions in regards to your VHS ESPixelPOP WLED controller kit simply contact me via the VHS talk site (<https://talk.vanhack.ca/>)